

# TL-62

## Steam Trap Flanged Ends

- Material: Cast Iron
- Size: 1/2"~2"

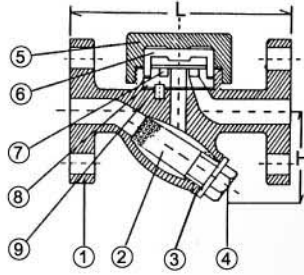

### Material list

NO	Parts name	Material
1	Body	Cast Iron
2	Screen	SUS 304
3	Gasket	NON-Asbestos
4	Nut	Cast Iron
5	Body cap	Cast Iron
6	Nut	Cast Iron
7	Washer	AISI 420
8	Disc	SUS 304
9	Parking	NON-Asbestos

### Dimensions

UNIT : M/M

MM	INCH	L	H	KG
15	1/2"	145	68	3
20	3/4"	160	75	3.6
25	1"	170	87	5
32	1 1/4"	205	110	7.5
40	1 1/2"	205	110	9
50	2"	240	115	10

# TL-63

## Steam Trap Screwed Ends

- Material: Cast Iron
- Size: 1/2"~2"

### Material list

NO	Parts name	Material
1	Body	Cast Iron
2	Screen	SUS 304
3	Gasket	NON-Asbestos
4	Nut	Cast Iron
5	Body cap	Cast Iron
6	Nut	Cast Iron
7	Washer	AISI 420
8	Disc	SUS 304
9	Parking	NON-Asbestos

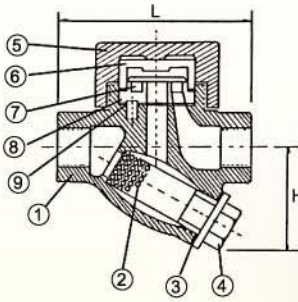

### Dimensions

UNIT : M/M

MM	INCH	L	H	KG
15	1/2"	98	68	1.8
20	3/4"	105	75	2
25	1"	115	88	2.5
32	1 1/4"	170	115	4.5
40	1 1/2"	170	115	5
50	2"	200	120	6.8

# TL-63SS

## Steam Trap Screwed Ends

- Material: CF8M PN40 / ANSI-600LB
- Size: 3/8"~1"

### Material list

NO	Parts name	Material
1	Body	A351-CF8M
2	Disc	AISI 420
3	Cap	A351-CF8M
4	Screen	SUS 304
5	Strainer cap	A351-CF8M

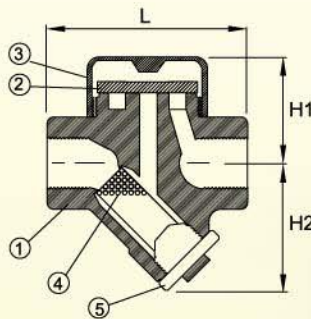

### Dimensions

UNIT : M/M

INCH	L	H1	H2	KG
3/8"	78	46	53	1
1/2"	78	46	53	1
3/4"	88	49	57	1.1
1"	98	51	63	1.4