

PERFORMANCE

Operating Pressure Range: 40 to 120 PSIG.

Maximum Allowable Working Pressure: 150PSIG.

Maximum Operating Pressure: 120PSIG.

Operating Media: Dry or lubricated non-corrosive gas.

Operating Temperature Standard: -40 °F to +200 °F

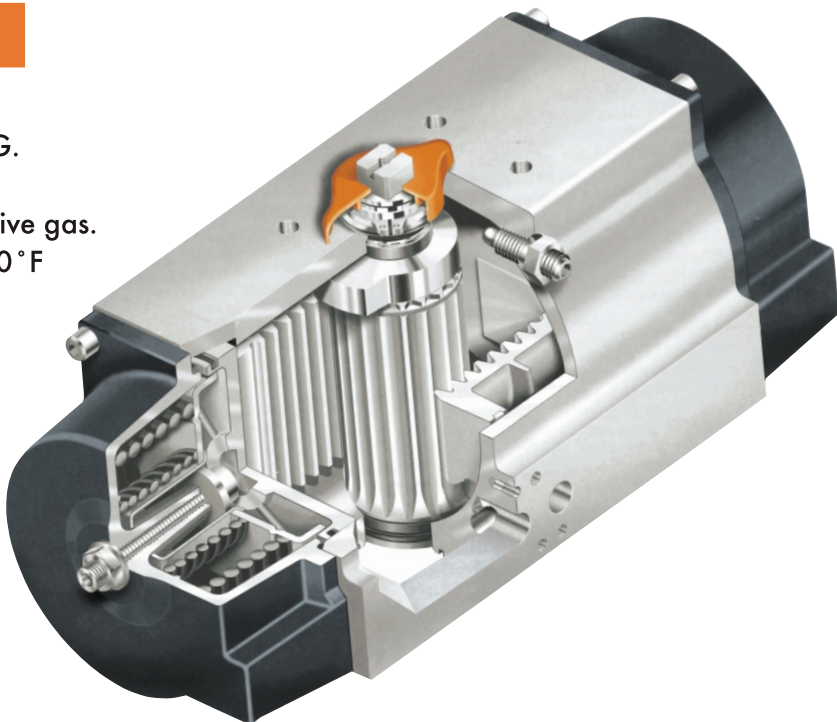

OPERATION

Double-Acting (Top View)

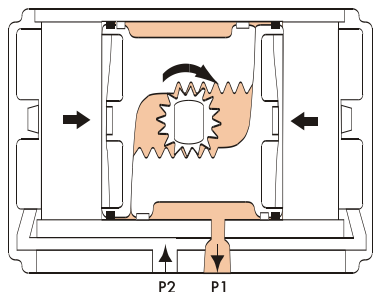

For clockwise output, apply pressure to P2, which force the pistons to move together. The volume between the pistons is exhausted at P1

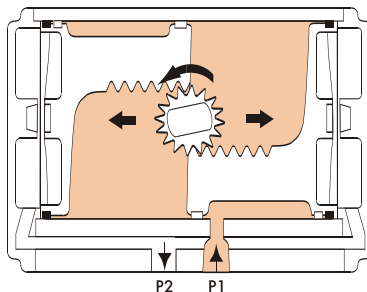

For counterclockwise output, apply pressure to P1, which force the pistons apart. The linear travel of the pistons is converted to a rotation of the drive shaft by the rack to pinion connection. The volume outside each piston is exhausted at P2.

*When required Reverse Rotation the pistons can be inverted in the housing resulting in a clockwise rotation when pressure is applied to P1.

Spring-Return (Top View)

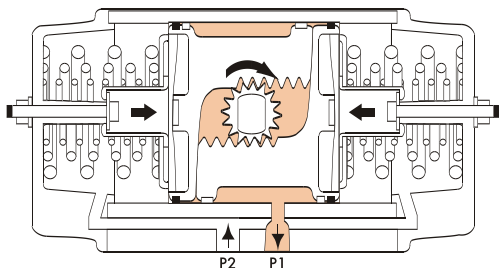

For clockwise output, the volume between the pistons is exhausted at P1, causing the springs to force the pistons together. The volume outside the pistons is vented at P2.

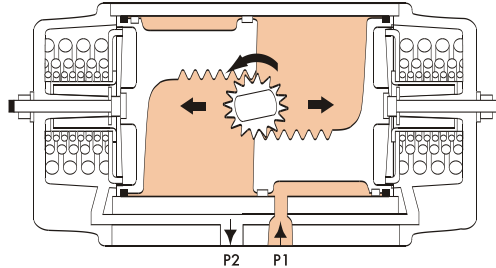

For counterclockwise output, apply pressure to P1, which force the pistons apart and compress the springs. The linear travel of the pistons is converted to a rotation of the drive shaft by the rack to pinion connection. The volume outside each piston is exhausted at P2.

*When required, Reverse Rotation the pistons can be inverted in the housing resulting in a clockwise rotation when pressure is applied to P1 and a counterclockwise rotation when P1 is vented.

CONSTRUCTION

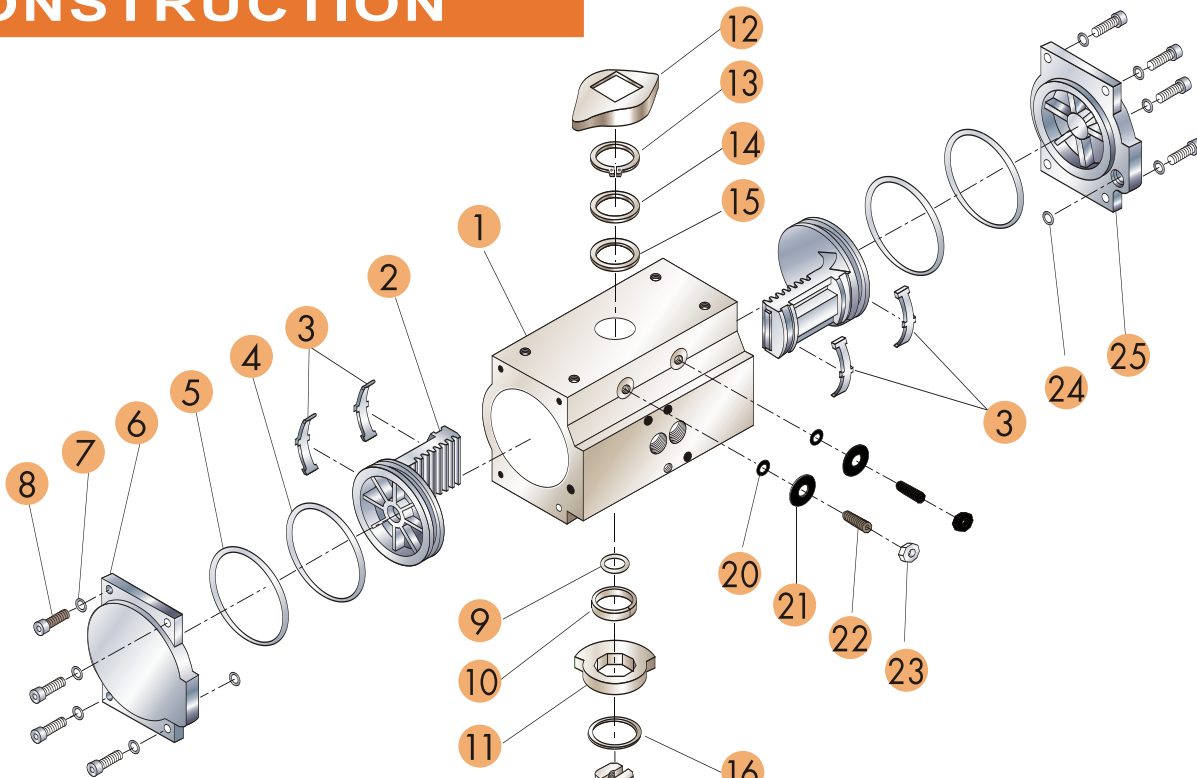

- 1 BODY: Extruded aluminum alloy (Hard anodized)
- 2 PISTONS: Die cast aluminum alloy
- 3 BEARING: Nylon
- 4 O-RING: Buna-N
- 5 O-RING: Buna-N
- 6 END CAP(L): Die cast aluminum alloy
- 7 WASHER: Stainless steel
- 8 CAP SCREW: Stainless steel
- 9 O-RING: Buna-N
- 10 BEARING: Nylon
- 11 STOP CAM: Sinteral steel
- 12 PISTON INDICATOR: Polyethylene

- 13 RETAINING RING: Stainless steel
- 14 WASHER: Stainless steel
- 15 BEARING: Nylon
- 16 RETAINING RING: Stainless steel
- 17 PINION: Carbon steel (Electroless nickel plated)
- 18 BEARING: Nylon
- 19 O-RING: Buna-N
- 20 O-RING: Buna-N
- 21 WASHER: Stainless steel
- 22 STOP SCREW: Stainless steel
- 23 NUT: Stainless steel
- 24 O-RING: Buna-N
- 25 END CAP(R): Die cast aluminum alloy

TRAVEL ADJUSTMENT

ZIPSON Z-Series actuators feature bi-directional pinion travel stops. Side located stops allow a full $\pm 5^\circ$ of valve travel adjustment, giving a guaranteed range of adjustment between 80° and 100° of actuator travel. These travel stops are designed to absorb the maximum rated torque of the actuator and the maximum impact loads associated with recommended stroke speed.

Standard Assembly

Adjustment of the counterclockwise and clockwise rotation limits are accomplished by turning the respective left and right stop adjustment screws to reduce or increase output rotation.

Travel Adjustment Range

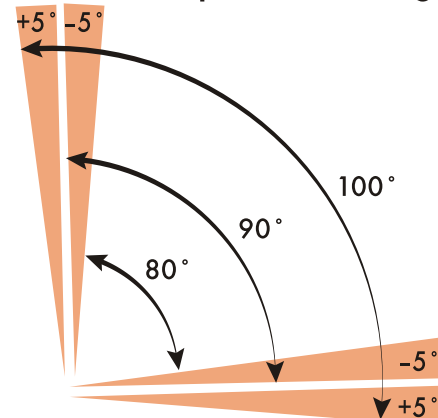

ADAPTOR

FEATURES

- Reduce Actuators ISO Output Shaft Broached Square Drive to Smaller ISO Square Stems
- Iron-Based Powdered Metal Construction for High Strength

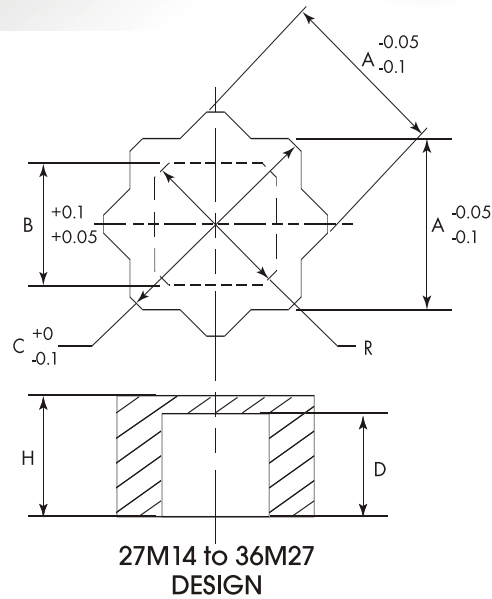
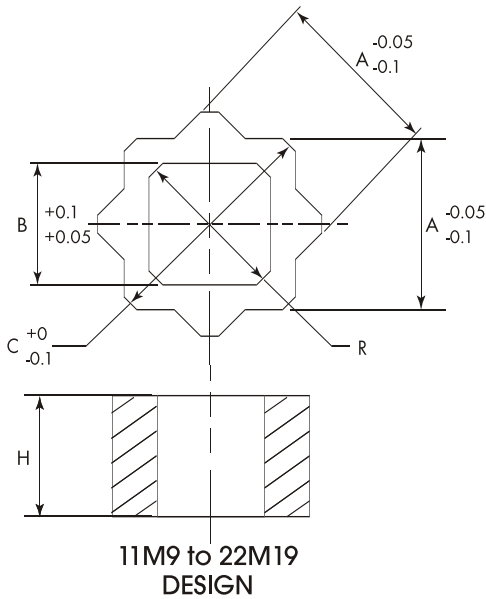
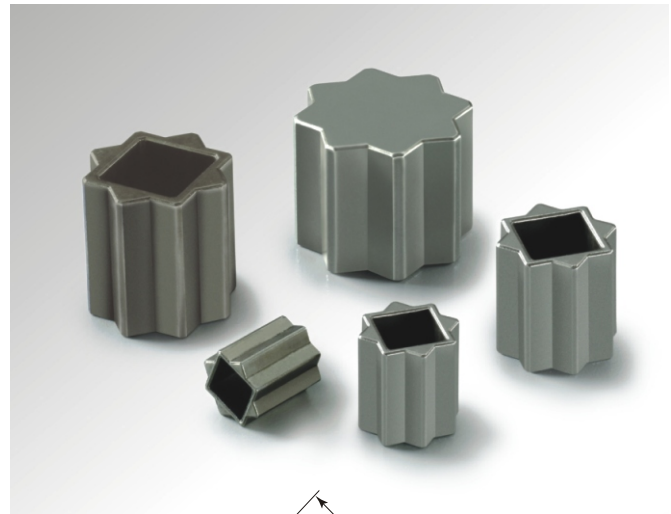

DOUBLE-SQUARE INSERT DIMENSIONS (UNIT: MM)

| INSERT | A | B | C | D | H | R |
|--------|----|----|------|------|------|------|
| 11M9 | 11 | 9 | 15.0 | N/A | 17.0 | 12.5 |
| 14M9 | 14 | 9 | 19.1 | N/A | 20.0 | 12.5 |
| 14M11 | 14 | 11 | 19.1 | N/A | 20.0 | 14.5 |
| 17M9 | 17 | 9 | 23.1 | N/A | 24.0 | 12.5 |
| 17M11 | 17 | 11 | 23.1 | N/A | 24.0 | 14.5 |
| 17M14 | 17 | 14 | 23.1 | N/A | 24.0 | 19.2 |
| 22M11 | 22 | 11 | 29.6 | N/A | 30.0 | 14.5 |
| 22M14 | 22 | 14 | 29.6 | N/A | 30.0 | 19.2 |
| 22M17 | 22 | 17 | 29.6 | N/A | 30.0 | 23.3 |
| 22M19 | 22 | 19 | 29.6 | N/A | 30.0 | 25.8 |
| 27M14 | 27 | 14 | 36.0 | 27.0 | 29.0 | 19.2 |
| 27M17 | 27 | 17 | 36.0 | 27.0 | 29.0 | 23.3 |
| 27M22 | 27 | 22 | 36.0 | 27.0 | 29.0 | 30.0 |
| 36M19 | 36 | 19 | 48.0 | 33.0 | 35.0 | 25.8 |
| 36M27 | 36 | 27 | 48.0 | 33.0 | 35.0 | 37.0 |

DIMENSIONS

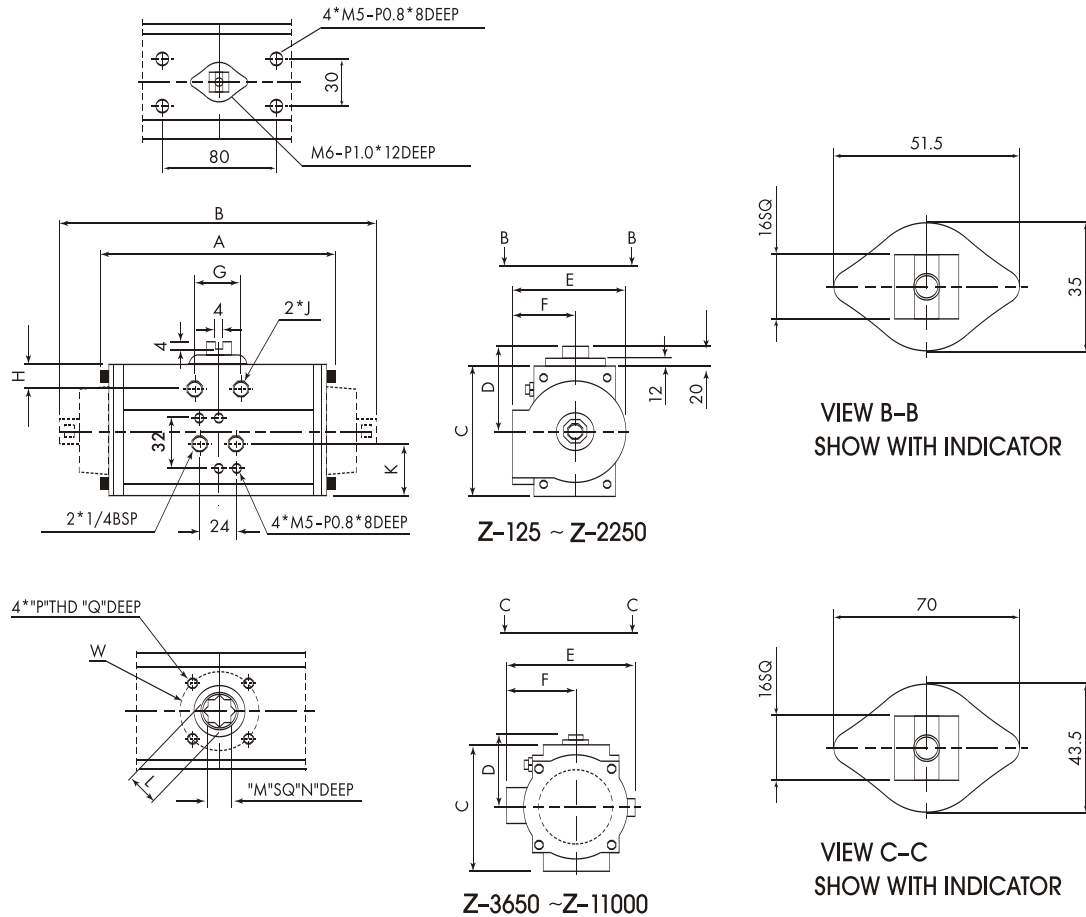

(UNIT: MM)

| Model | ISO PATTERN | OUTPUT TORQUE AT 80PSI AIR | A | B | C | D | E | F | G | H | J |
|---------|-------------|----------------------------|-------|-------|-------|-------|-------|-------|------|------|-----------|
| Z-125 | F04 | 125IN-LB | 120.0 | -- | 64.0 | 52.5 | 62.2 | 33.7 | 24.0 | 11.0 | MxP0.8 |
| Z-250 | F04 or F05 | 250IN-LB | 144.3 | 194.6 | 79.0 | 57.7 | 81.4 | 47.8 | 32.5 | 12.6 | M5xP0.8 |
| Z-450 | F05 & F07 | 450IN-LB | 149.2 | 205.6 | 98.0 | 67.4 | 95.0 | 51.5 | 32.5 | 13.8 | M6xP1.0 |
| Z-1000 | F05 & F07 | 1000IN-LB | 183.0 | 250.0 | 121.0 | 79.2 | 119.0 | 64.5 | 46.2 | 16.6 | M8xP1.25 |
| Z-2250 | F07 & F10 | 2250IN-LB | 259.6 | 355.0 | 141.0 | 89.5 | 140.5 | 75.5 | 54.0 | 18.6 | M10xP1.5 |
| Z-3650 | F10 & F12 | 3650IN-LB | 304.3 | 422.0 | 176.0 | 99.1 | 185.2 | 105.5 | 79.7 | 27.3 | M12xP1.75 |
| Z-5000 | F10 & F12 | 5000IN-LB | 364.4 | 487.0 | 196.0 | 116.5 | 204.8 | 107.8 | 79.4 | 28.3 | M12xP1.75 |
| Z-11000 | F14 | 11000IN-LB | 490.0 | 642.0 | 243.7 | 138.5 | 238.2 | 125.0 | 95.3 | 35.8 | M16xP2.0 |

| Model | ISO PATTERN | OUTPUT TORQUE AT 80PSI AIR | K | L | M | N | P | Q | W |
|---------|-------------|----------------------------|-------|------|------|------|--------------------|-----------|-------------|
| Z-125 | F04 | 125IN-LB | 23.5 | 12.5 | 9.0 | 10.0 | M5xP0.8 | 8.0 | 42.0 |
| Z-250 | F04 or F05 | 250IN-LB | 29.7 | 14.5 | 11.0 | 17.0 | M5xP0.8/M6xP1.0 | 8.0/10.0 | 42.0/50.0 |
| Z-450 | F05 & F07 | 450IN-LB | 30.2 | 18.8 | 14.0 | 21.0 | M6xP1.0/M8xP1.25 | 10.0/12.0 | 50.0/70.0 |
| Z-1000 | F05 & F07 | 1000IN-LB | 33.5 | 23.0 | 17.0 | 25.5 | M6xP1.0/M8xP1.25 | 10.0/12.0 | 50.0/70.0 |
| Z-2250 | F07 & F10 | 2250IN-LB | 39.0 | 29.5 | 22.0 | 31.0 | M8xP1.25/M10xP1.5 | 12.0/15.0 | 70.0/102.0 |
| Z-3650 | F10 & F12 | 3650IN-LB | 97.4 | 35.5 | 27.0 | 35.0 | M10xP1.5/M12xP1.75 | 15.0/19.0 | 102.0/125.0 |
| Z-5000 | F10 & F12 | 5000IN-LB | 99.0 | 35.5 | 27.0 | 35.0 | M10xP1.5/M12xP1.75 | 15.0/19.0 | 102.0/125.0 |
| Z-11000 | F14 | 11000IN-LB | 124.7 | 47.5 | 36.0 | 45.0 | M16xP2.0 | 24.0 | 140.0 |

Z-SERIES

Pneumatic Rack & Pinion Actuators TORQUE RATINGS (IN-LbS)

Double-Acting Actuators

| Model | Air Torque Output at Operating Pressure-Psig | | | | |
|---------|--|------|-------|-------|-------|
| | 40 | 60 | 80 | 100 | 120 |
| Z-125 | 63 | 94 | 125 | 156 | 188 |
| Z-250 | 125 | 187 | 250 | 312 | 375 |
| Z-450 | 225 | 337 | 450 | 562 | 675 |
| Z-1000 | 500 | 750 | 1000 | 1250 | 1500 |
| Z-2250 | 1125 | 1687 | 2250 | 2812 | 3375 |
| Z-3650 | 1825 | 2738 | 3650 | 4563 | 5475 |
| Z-5000 | 2500 | 3750 | 5000 | 6250 | 7500 |
| Z-11000 | 5500 | 8250 | 11000 | 13750 | 16500 |

Spring-Return Actuators

| Model | Number | Spring Torque Output | | Air Torque Output at Operating Pressure-Psig | | | | | | | | | |
|---------|--------|----------------------|------------|--|------|-------|------|-------|------|-------|------|-------|-------|
| | | | | 40 | | 60 | | 80 | | 100 | | 120 | |
| | | Basic | Spring Set | Start | End | Start | End | Start | End | Start | End | Start | End |
| Z-250 | 2 | 69 | 45 | 76 | 47 | 138 | 109 | 201 | 172 | 263 | 234 | 326 | 312 |
| | 3 | 104 | 67 | | | 113 | 70 | 176 | 133 | 229 | 195 | 301 | 258 |
| | 4 | 140 | 90 | | | 88 | 31 | 151 | 93 | 213 | 156 | 276 | 218 |
| | 5 | 175 | 112 | | | | | 126 | 54 | 189 | 116 | 251 | 179 |
| | 6 | 209 | 135 | | | | | | | 164 | 77 | 227 | 139 |
| | Z-450 | 2 | 126 | 81 | 135 | 83 | 248 | 196 | 361 | 309 | 473 | 421 | 586 |
| | 3 | 190 | 121 | | | 203 | 125 | 316 | 238 | 428 | 350 | 541 | 463 |
| | 4 | 254 | 162 | | | 158 | 54 | 271 | 167 | 383 | 279 | 496 | 392 |
| | 5 | 317 | 202 | | | | | 226 | 96 | 339 | 209 | 451 | 321 |
| | 6 | 381 | 243 | | | | | | | 293 | 137 | 406 | 251 |
| Z-1000 | 2 | 279 | 179 | 300 | 184 | 549 | 433 | 798 | 682 | 1048 | 931 | 1297 | 1181 |
| | 3 | 418 | 270 | | | 449 | 278 | 698 | 526 | 947 | 775 | 1196 | 1025 |
| | 4 | 559 | 360 | | | 350 | 120 | 599 | 371 | 848 | 618 | 1097 | 867 |
| | 5 | 698 | 450 | | | | | 500 | 212 | 749 | 464 | 998 | 710 |
| | 6 | 839 | 540 | | | | | | | 650 | 304 | 899 | 557 |
| | Z-2250 | 2 | 659 | 394 | 690 | 395 | 1253 | 958 | 1816 | 1521 | 2379 | 2084 | 2939 |
| | 3 | 990 | 590 | | | 1034 | 591 | 1596 | 1154 | 2159 | 1717 | 2722 | 2280 |
| | 4 | 1320 | 787 | | | 816 | 226 | 1379 | 788 | 2029 | 1351 | 2505 | 1914 |
| | 5 | 1650 | 984 | | | | | 1161 | 424 | 1724 | 984 | 2287 | 1549 |
| | 6 | 1980 | 1181 | | | | | | | 1506 | 621 | 2069 | 1181 |
| Z-3650 | 2 | 1053 | 607 | 1152 | 659 | 2063 | 1570 | 2975 | 2482 | 3886 | 3393 | 4797 | 4305 |
| | 3 | 1573 | 912 | | | 1726 | 996 | 2637 | 1907 | 3549 | 2819 | 4460 | 3730 |
| | 4 | 2091 | 1217 | | | 1388 | 423 | 2300 | 1335 | 3211 | 2246 | 4123 | 3157 |
| | 5 | 2625 | 1519 | | | | | 1967 | 744 | 2878 | 1655 | 3789 | 2566 |
| | 6 | 3144 | 1824 | | | | | | | 2540 | 1082 | 3452 | 1994 |
| | Z-5000 | 2 | 1560 | 785 | 1590 | 803 | 2780 | 1990 | 3970 | 3180 | 5160 | 4380 | 6350 |
| | 3 | 2340 | 1180 | | | 2380 | 1200 | 3570 | 2400 | 4760 | 3590 | 5960 | 4780 |
| | 4 | 3130 | 1570 | | | 1980 | 414 | 3180 | 1600 | 4370 | 2800 | 5560 | 3990 |
| | 5 | 3910 | 1960 | | | | | 2780 | 815 | 3970 | 2010 | 5160 | 3200 |
| | 6 | 4690 | 2360 | | | | | | | 3570 | 1220 | 4760 | 2410 |
| Z-11000 | 2 | 3400 | 1720 | 3460 | 1760 | 6060 | 4360 | 8660 | 6960 | 11300 | 9560 | 13900 | 12200 |
| | 3 | 5100 | 2570 | | | 5200 | 2650 | 7790 | 5240 | 10400 | 7840 | 13000 | 10400 |
| | 4 | 6790 | 3430 | | | 4330 | 932 | 6930 | 3530 | 9520 | 6130 | 12100 | 8730 |
| | 5 | 8490 | 4290 | | | | | 6060 | 1810 | 8660 | 4410 | 11300 | 7010 |
| | 6 | 10200 | 5150 | | | | | | | 7790 | 2700 | 10400 | 5300 |